

Simplex Motions SC-Serie is a compact integrated motor drive unit series that incorporates brushless DC motor and control electronics in an open frame configuration.

This makes for a simple to use and cost optimized solution for OEM motion control applications.

Description:

The motor is of outer rotor design to optimize high torque and efficiency, thus eliminating the gearbox in many applications. The dynamic capabilities are substantially higher than continuous operation, which makes this product especially suitable for dynamic loads with high acceleration rates.

The control electronics is based on a digital signal processor to enable precise closed loop control of motor position and speed. The PID regulator also applies feed forward control to optimize performance. Ramping of position moves are supported with specified maximum speed, acceleration and deceleration. Output torque is limited to a configurable value.

Target control values can be obtained from several different interfaces; RS485 serial bus using the Modbus RTU protocol, quadrature encoder, step/dir interface (for step motor emulation) or analog input.

There are also a number of digital and analog inputs available to connect external sensors and actuators.

The interface for control and configuration relies on the Modbus RTU protocol with serial RS485 or RS232 physical connection. The RS485 support allows for a robust means of connecting several units to the same interface bus.

Setup and configuration is further simplified with a PC software that enables readout and setting of all configuration data, as well as easy testing of drive functions. Together with a built-in signal recorder it is possible to investigate dynamic behavior closely.

Integration of motor and electronics into the same unit minimizes issues with electromagnetic interference and cabling, and also simplifies configuration and initial setup. In a minimal setup for external control only 2 wires of power and 3 wires of serial communication have to be routed to the motor.



- Integrated drive electronics with 4096 positions/revolution position sensor
- PID regulator for control of torque, speed or position.
- Ramp controlled moves in position with set speed and acceleration
- Protection features for current, torque, voltage and temperature
- Serial RS485 (or RS232) interface with Modbus RTU protocol.
- Quadrature encoder input
- Interface signals for step motor emulation (step/direction)
- Up to 8 digital inputs and 4 analog inputs
- 4 digital outputs capable of 30V/1A, with pulse, PWM or RC servo pulse output.
- PC based software for setup and testing
- API libraries for custom software control (Windows .NET, Labview, Linux)
- Cost efficient

1 Table of contents

1	Table of contents	2
	Technical data	3
1.1	SC010A Technical data	4
1.1.1	SC010A Motor output power.....	4
1.1.2	SC010A Physical dimensions	4
1.2	SC020A Technical data	5
1.2.1	SC020A Motor output power.....	5
1.2.2	SC020A Physical dimensions	5
1.3	SC040A Technical data	6
1.3.1	SC040A Motor output power.....	6
1.3.2	SC040A Physical dimensions	6
1.4	Electrical connections.....	7

2 Technical data

The following table specifies important characteristics and limits for the SimplexMotion SC010A, SC020A and SC040A product.

Motor specifications		SC010A	SC020A	SC040A
Torque	At nominal rpm	60 mNm (8.5 oz-in)	120 mNm (17 oz-in)	200 mNm (28.0 oz-in)
	Continuous stall	50 mNm (7.1 oz-in)	100 mNm (14 oz-in)	190 mNm (29.8 oz-in)
	Peak	200 mNm (28.0 oz-in)	400 mNm (46 oz-in)	800 mNm (113 oz-in)
Speed	Nominal	4000 rpm	4000 rpm	4000 rpm
	Peak	6000 rpm	6000 rpm	6000 rpm
Power	Continuous	25 W (in open air)	50 W (in open air)	80 W (in open air)
	Peak	75 W	150 W	240 W
Efficiency	Up to	70%	75%	80%
Rotor inertia		3.43 E-6 kgm ²	12.60 E-6 kgm ²	33.00 E-6 kgm ²
Electrical specifications				
Supply voltage	Min	8 V	8 V	12 V
	Typical	12 V	12 V	24 V
	Max	15 V (absolute maximum 20V)	15 V (absolute maximum 20V)	28 V (absolute maximum 30V)
Supply Current	Idle	0.05 A	0.05 A	0.05 A
	Continuous	3.0 A	5.6 A	4.2 A
	Peak	9.0 A	16.7 A	12.5 A
Controller specifications				
Encoder	Counts per revolution	4096		
	Resolution	0.09°		
	Precision	+/- 0.25°		
Switching frequency		32 kHz		
Motor commutation	Method	space vector modulation with field orientation control		
	Rate	16 kHz		
PID controller	Sample rate	2 kHz		
	Control	Torque, Position, Speed		
Ramping control	Speed	speed limit + controlled acceleration/deceleration		
	Position	controlled speed + acceleration/deceleration		
Protection		overcurrent, torque, voltage, temperature, locked shaft		
Status indicator		green + red light, blink pattern provides status		
Interfaces	RS485/RS232 TTL	max 115kBit/s, Modbus RTU protocol		
	Step motor interface	direction/step inputs, 5V logic inputs, max 2.2MHz.		
	Quadrature encoder	5V logic inputs, max 2.2MHz		
	Analog control	voltage 0...+3.3V		
Digital Inputs, IN1-4	Maximum voltage	-0.5...+30V		
	Low/high threshold	Configurable 0...+3.3V		
	Pull up/down resistor	10kOhm to +3.3V or GND, or disabled		
Digital inputs, IN5-8	Maximum voltage	-0.5...+6.0V		
	Low/high threshold	Low < 0.7V, high > 2.4V		
	Pull up resistor	None		
Analog inputs, IN1-4	Maximum voltage	-0.5...+30V		
	Input range	0...+3.3V		
	Resolution	16bits		
	Accuracy	10bits		
Digital outputs, OUT1-4	Input impedance	300kOhm with pullup/down disabled		
	Control	Logic, single pulse, PWM, RC servo control		
	Output circuit	Open collector, transistor.		
	Maximum voltage	-0.5...+30V		
	Maximum current	1A		
	Pull up/down resistor	10kOhm to +3.3V or GND, or disabled		
Mechanical specifications				
Dimensions	Body (L x W x H)	36 x 28 x 38 mm	47 x 35 x 45 mm	52 x 42 x 52 mm
	Shaft	D4 x 16 mm	D4 x 16 mm	D5 x 18 mm
Mounting		M2.5 screws in front	M3 screws in front,	M3 screws in front,
Weight		75 g (2.65 oz)	160 g (5.65 oz)	240 g (8.5 oz)
Shaft loading	Radial load	75N	100N	125N
	Axial load	20N	30N	40N
Ambient specifications				
Protection class		IP00, needs external protection	IP00, needs external protection	IP00, needs external protection
Temperature	Operating	0...+40°C	0...+40°C	0...+40°C
	Derating of output power	0.42 W/C.	0.84 W/C.	1.34 W/C
	Storage	-40...+85 °C	-40...+85 °C	-40...+85 °C

2.1 SC010A Technical data

2.1.1 SC010A Motor output power

The SC010A handles up to 25W continuous mechanical output power in normal conditions (mounted with free flowing air around the unit, ambient temperature below 40°C). But it is possible to extract several times more power during short intervals. These higher power ratings are limited by:

- Total power limited to 75W (3 times nominal continuous operating limits)
- The maximum provided torque from the motor (0.2Nm)
- The maximum rotational speed, dependent on supply voltage.

The diagram below shows the operating region of the unit.

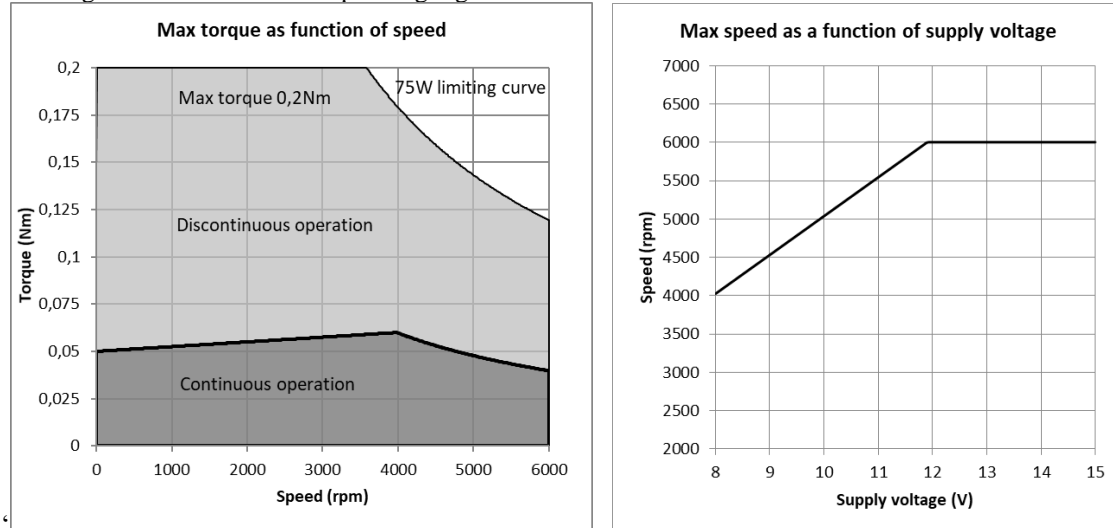

It is possible to extract higher continuous output power levels if the cooling is optimized, for example by fixing the unit to a large metallic structure that can conduct heat away from the unit.

2.1.2 SC010A Physical dimensions

The mechanical implementation utilizes an aluminum extrusion that holds the motor and electronics and allows mounting of the unit. Mounting should be done to facilitate free air moving around the unit to allow sufficient cooling. Thermal properties can also be enhanced by mounting the unit onto a large metallic structure that can conduct heat away from the drive. Specified technical data has been verified with minimal heat conduction and free air flowing around the drive. With efficient conduction of heat from the drive it is possible to extract higher output power ratings. Make sure to use the thermal protection feature to not damage the drive when running close to its limits.

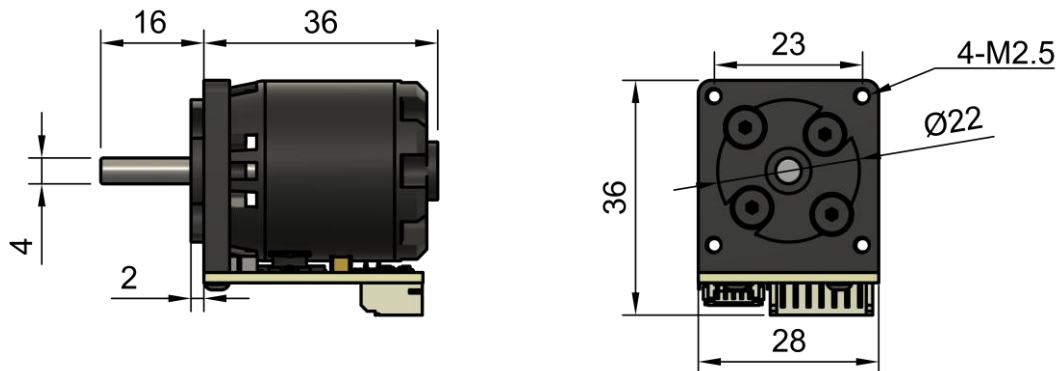

Positive rotational direction is clockwise rotation when looking at the motor front plate (as shown above in the picture to the right).

Unit is mounted by M2.5 screws in the front. There are 4pcs of M2.5 threaded holes for this purpose.

2.2 SC020A Technical data

2.2.1 SC020A Motor output power

The SC020A handles up to 50W continuous mechanical output power in normal conditions (mounted with free flowing air around the unit, ambient temperature below 40°C). But it is possible to extract several times more power during short intervals. These higher power ratings are limited by:

- Total power limited to 150W (3 times nominal continuous operating limits)
- The maximum provided torque from the motor (0.4Nm)
- The maximum rotational speed, dependent on supply voltage.

The diagram below shows the operating region of the unit.

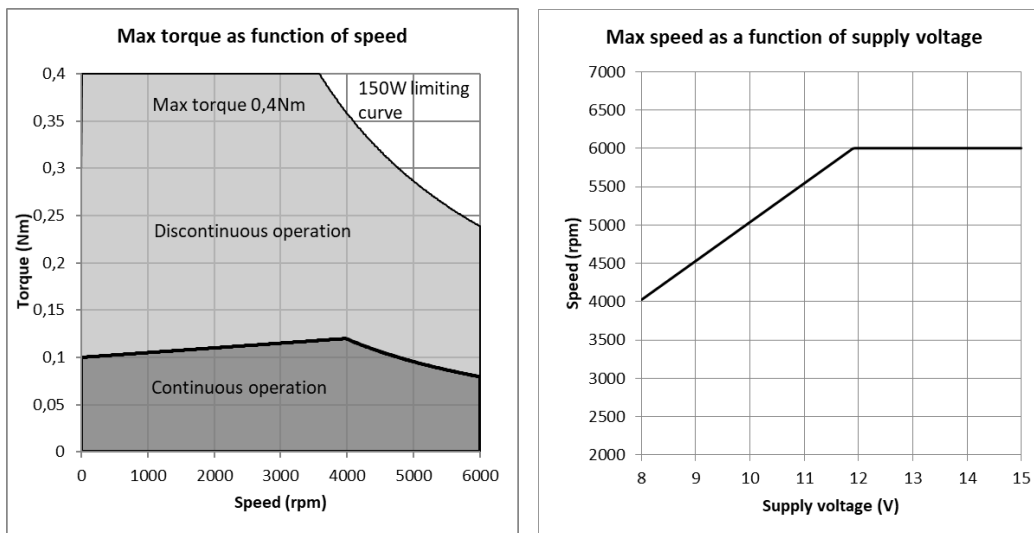

It is possible to extract higher continuous output power levels if the cooling is optimized, for example by fixing the unit to a large metallic structure that can conduct heat away from the unit.

2.2.2 SC020A Physical dimensions

The mechanical implementation utilizes an aluminum extrusion that holds the motor and electronics and allows mounting of the unit. Mounting should be done to facilitate free air moving around the unit to allow sufficient cooling. Thermal properties can also be enhanced by mounting the unit onto a large metallic structure that can conduct heat away from the drive. Specified technical data has been verified with minimal heat conduction and free air flowing around the drive. With efficient conduction of heat from the drive it is possible to extract higher output power ratings. Make sure to use the thermal protection feature to not damage the drive when running close to its limits.

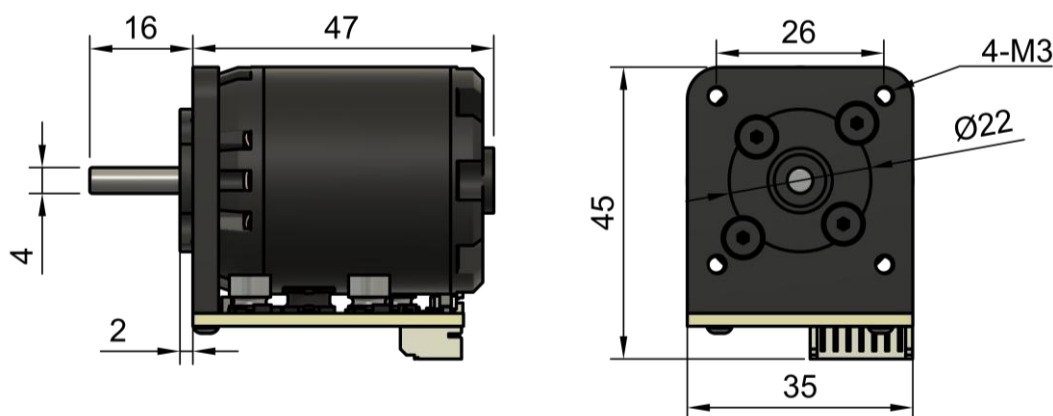

Positive rotational direction is clockwise rotation when looking at the motor front plate (as shown above in the picture to the right). Unit is mounted by M3 screws in the front. There are 4pcs of M3 threaded holes for this purpose.

2.3 SC040A Technical data

2.3.1 SC040A Motor output power

The SC040A handles up to 80W continuous mechanical output power in normal conditions (mounted with free flowing air around the unit, ambient temperature below 40°C). But it is possible to extract several times more power during short intervals. These higher power ratings are limited by:

- Total power limited to 240W (3 times nominal continuous operating limits)
- The maximum provided torque from the motor (0.8Nm)
- The maximum rotational speed, dependent on supply voltage.

The diagram below shows the operating region of the unit.

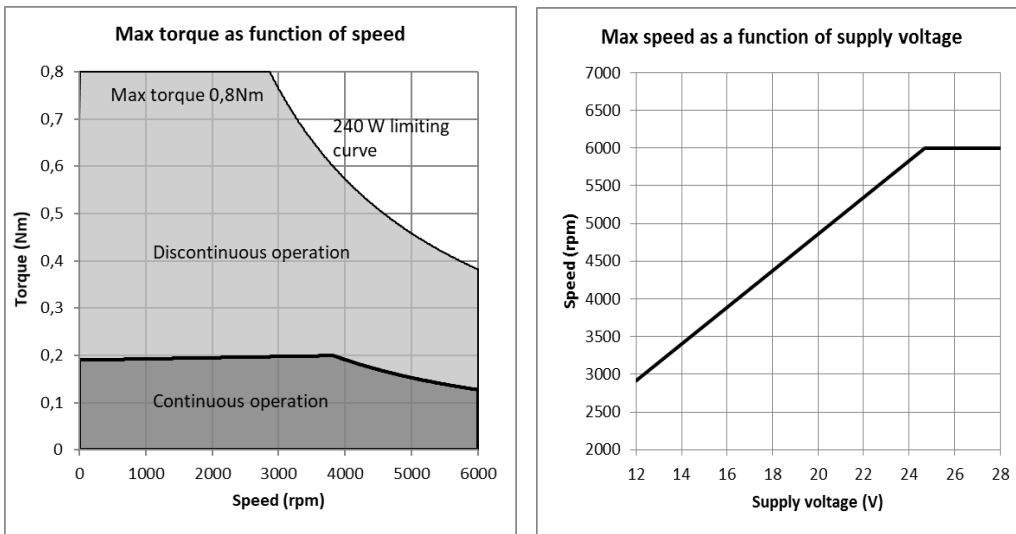

It is possible to extract higher continuous output power levels if the cooling is optimized, for example by fixing the unit to a large metallic structure that can conduct heat away from the unit.

2.3.2 SC040A Physical dimensions

The mechanical implementation utilizes an aluminum extrusion that holds the motor and electronics and allows mounting of the unit. Mounting should be done to facilitate free air moving around the unit to allow sufficient cooling. Thermal properties can also be enhanced by mounting the unit onto a large metallic structure that can conduct heat away from the drive. Specified technical data has been verified with minimal heat conduction and free air flowing around the drive. With efficient conduction of heat from the drive it is possible to extract higher output power ratings. Make sure to use the thermal protection feature to not damage the drive when running close to its limits.

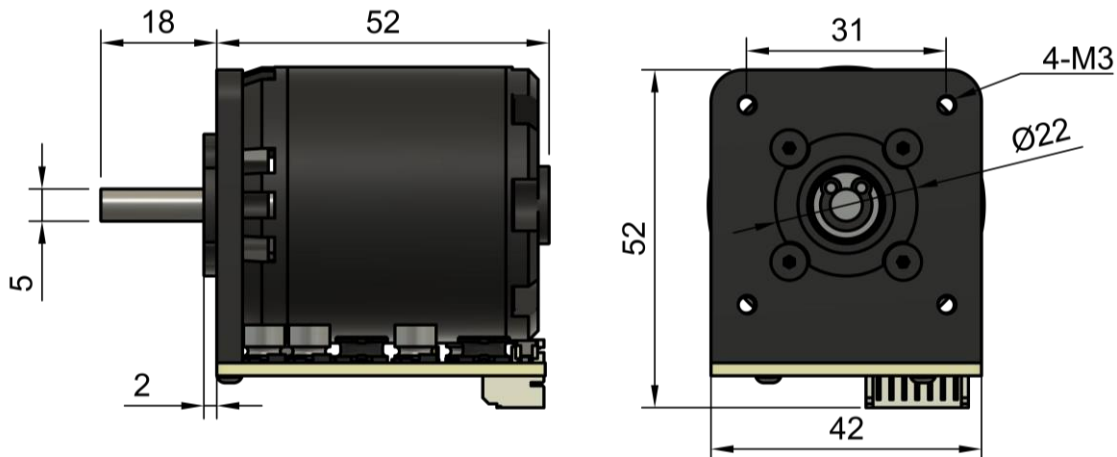

Positive rotational direction is clockwise rotation when looking at the motor front plate (as shown above in the picture to the right). Unit is mounted by M3 screws in the front. There are 4pcs of M3 threaded holes for this purpose.

2.4 Electrical connections

There are one electrical connections to the SC-Series:

- 14 polarity housing connector

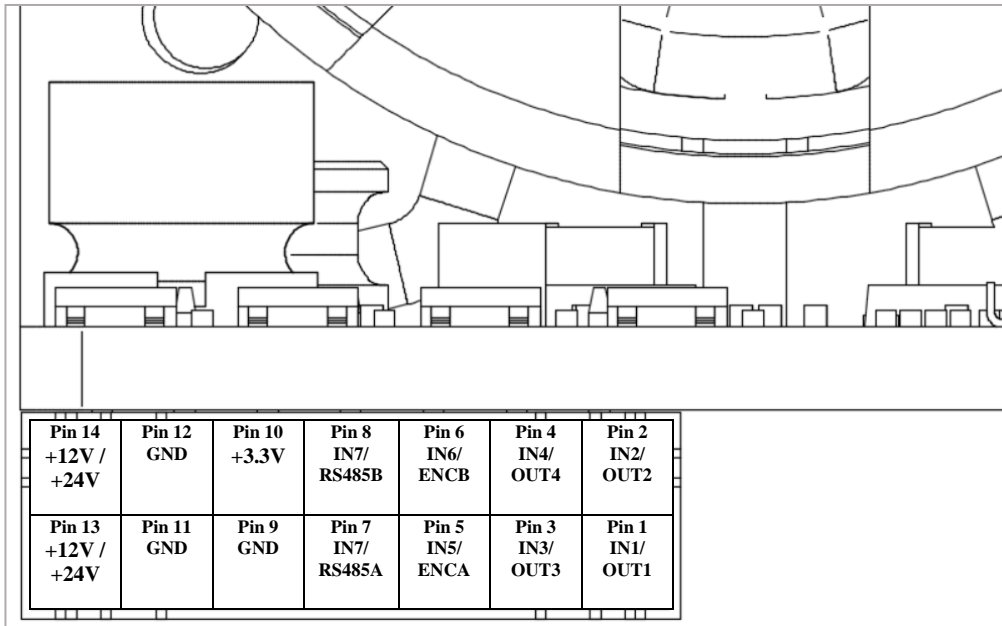

The housing connector is from JST Sales America Inc, part number PHDR-14VS (Available as 455-1172-ND from www.digikey.com).

Pin	Name	SC010A and SC020A	SC040A
1	IN1/OUT1	Digital/Analog input and/or output (open collector type, max 30V/1A)	
2	IN2/OUT2	Digital/Analog input and/or output (open collector type, max 30V/1A)	
3	IN3/OUT3	Digital/Analog input and/or output (open collector type, max 30V/1A)	
4	IN4/OUT4	Digital/Analog input and/or output (open collector type, max 30V/1A)	
5	IN5/ENCA	Digital input or Encoder input (0...+3.3V)	
6	IN6/ENCB	Digital input or Encoder input (0...+3.3V)	
7	IN7/RS485A	Digital input or RS485 Modbus communication (0...+3.3V). RX for RS232 usage.	
8	IN8/RS485B	Digital input or RS485 Modbus communication (0...+3.3V). TX for RS232 usage.	
9	GND	Ground reference for all input/outputs	
10	+3.3V	+3.3V supply voltage output, max 100mA. (Not intended as voltage input).	
11	GND	Power supply ground	
12	GND	Power supply ground	
13	+12V / +24V	Power supply input +12V	Power supply input +24V
14	+12V / +24V	Power supply input +12V	Power supply input +24V